



1902 Mc Gaw
 Irvine, CA 92614 USA
 P: 949-567-9000
 F: 949-567-9010
 www.cp-carrillo.com

STANDARD CONNECTING ROD SPEC SHEET

To be filled out by CP-Carrillo LLC		Customer:			
ERN:		Phone:			
FA:		Date:		Sales Rep:	
Reference Part No.:					
New Part No.:					

ENGINE DATA

Engine Type (Code): (e.g. Chevy Small Block, Subaru EJ25, etc.)					
Application: (e.g. Road Race, Drag Race, Sprint Car, etc.)					
No. of Cylinders:		-			
Bore:		<input type="radio"/> in / <input type="radio"/> mm			
Stroke:		<input type="radio"/> in / <input type="radio"/> mm			
Max. Power Output @crank:		<input type="radio"/> HP / <input type="radio"/> kW			
Speed @ max Power:		RPM			
Max. Torque @crank:		<input type="radio"/> ftlb / <input type="radio"/> Nm			
Speed @ max Torque:		RPM			
Max. Engine speed:		RPM			
Max. Engine over rev:		RPM			
Max. Cylinder pressure:		<input type="radio"/> psi / <input type="radio"/> bar			
Boost pressure: (if applicable)		<input type="radio"/> psi / <input type="radio"/> bar			
Compression ratio:		-			
Fuel Type: (e.g. Alcohol, Race gas, etc.)					
NOS:	<input type="radio"/> no	<input type="radio"/> yes			
					HP
Does engine have Oil squirters	<input type="radio"/> no	<input type="radio"/> yes			
Piston Assembly Weight (=piston+pin+rings+locks)		g			

CONNECTING ROD DATA

Target weight:	Total:		g	Recip.		g
Required Durability	<input type="radio"/> mi / <input type="radio"/> h / <input type="radio"/> Load Cycles					
Rod Bearing Part No.:						
Preferred Bolt Size:						
Preferred Bolt Material:	CARR			WMC		
Wrist Pin OD:		<input type="radio"/> in / <input type="radio"/> mm				
PE Bushing:	<input type="radio"/> no <input type="radio"/> yes					
Preferred Beam Type:	<input type="radio"/> H-Beam <input type="radio"/> A-Beam <input type="radio"/> Super A-Beam					
Guidance:	<input type="radio"/> Piston <input type="radio"/> BE <input type="radio"/> Dual					
Oil hole position:	<input type="radio"/> Top (12 o'clock) <input type="radio"/> Bottom					
	<input type="radio"/> 10 & 2 o'clock <input type="radio"/> None					



1902 Mc Gaw
 Irvine, CA 92614 USA
 P: 949-567-9000
 F: 949-567-9010
 www.cp-carrillo.com

General Dimensions			Bearing Tang	
	inches	mm	Configuration:	BL1 BL2
A			inches	mm
B			J	
C			K	
D			L	
E			M	
F			N	
G			P	
H			Q	
I			R	
Upgrade Features			S	
1	Annular Groove	<input type="radio"/> yes <input type="radio"/> no	Comments:	
2	Lipped Cap	<input type="radio"/> yes <input type="radio"/> no		
3	Bushing	<input type="radio"/> BeCu <input type="radio"/> Toughmet		
4	PE Lapped Finish	<input type="radio"/> yes <input type="radio"/> no		
5	BE Lapped Finish	<input type="radio"/> yes <input type="radio"/> no		
6	FPO	<input type="radio"/> yes <input type="radio"/> no		
7	Serialization	<input type="radio"/> yes <input type="radio"/> no		
8	Custom Laser Mark	<input type="radio"/> yes <input type="radio"/> no		

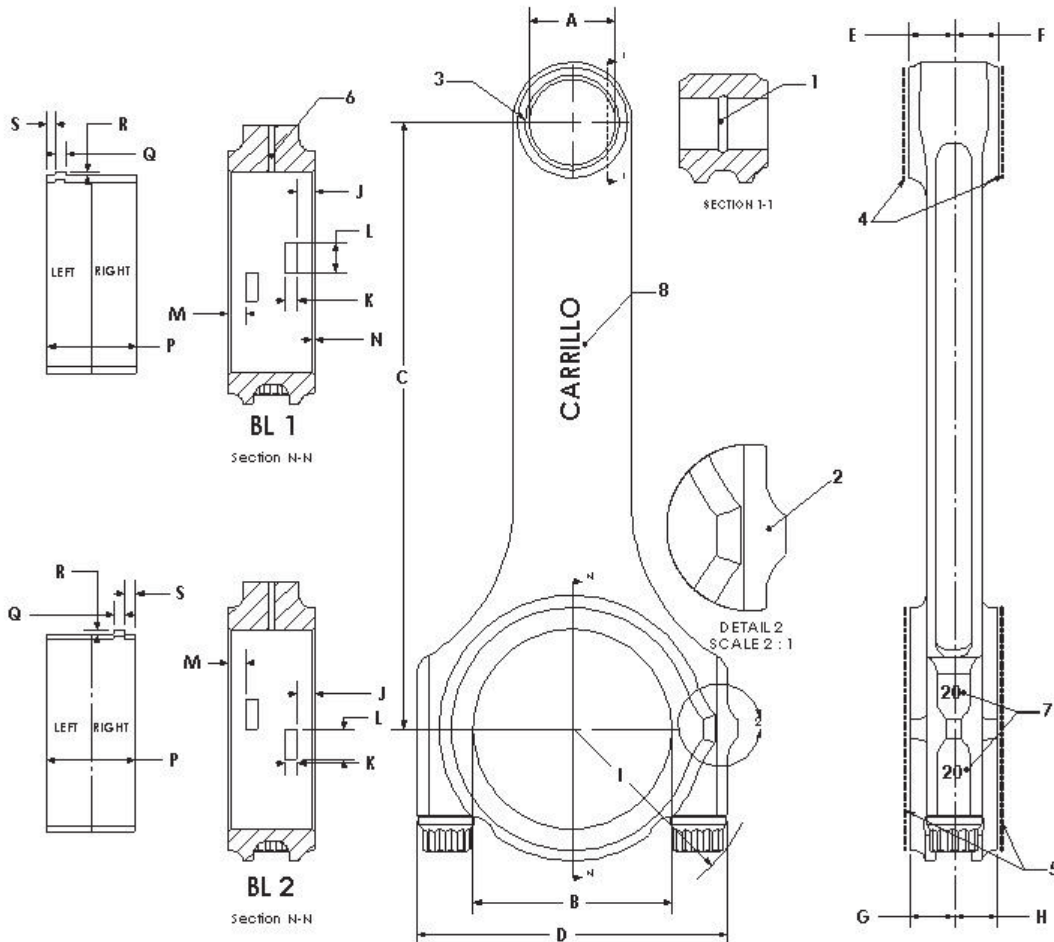



Custom Order Release

Please be advised that in placing this order for custom manufactured merchandise you are accepting full responsibility for the correctness and accuracy of all pertinent ordering information. Further, be advised that by filling out and signing this form you are affirming the correctness and accuracy of the information contained herein and authorizing Motor State Distributing to order this custom merchandise. Once this form has been signed, the purchaser assumes full responsibility for paying for the custom merchandise and no refund will be issued unless it can be shown that any errors or defects were the fault of the manufacturer and not caused by erroneous information.

As a rule, custom orders cannot be cancelled once the order is placed with the manufacturer. All custom orders are subject to freight and handling charges from the manufacturer.

No returns will be accepted on custom-built items.

Sales Contact At Motor State _____

Customer Number _____

Company Name _____

Address _____

City _____ State _____ Zip _____

Phone _____

Fax _____

Email _____

Print Your Name _____ Date _____

Authorized Signature _____

If you are submitting this form electronically, your digital signature must be added last. Once signed, this form becomes non-editable. Please double check all items first.

Motor State Distributing

8300 Lane Drive, Watervliet MI 49098

web: www.motorstate.com | phone: 1-800-772-2678 | fax: 1-800-772-2618