



PICKUP TRUCK INFORMATION SHEET

Company name _____ Account No. _____

Address - Street _____

City - State - Zip _____

Order P.O. number _____ Fabric Choice _____

Customer name _____

Identification Information

Year _____ Make _____ Model _____

Std. Cab Ext'd Cab 2-Door 3-Door 4-Door

Short Bed Long Bed If unsure, bed length in inches _____

Standard Rear Wheels Dual Rear Wheels (Dually)

Aftermarket Accessories

NOTE - A photo and sketch must be sent with dimensions noted for any of these accessories. The photo will be returned if requested. This information is required to insure the best fit possible.

Grille Guard

Sun Visor

Push Bar

Shell or Cap on Bed

Winch on Front Bumper

Roll Bar / Light Bar

Bug Deflector on Hood

Spare Tire in Bed

Tool Box in Bed

Height above side of bed (inches) _____

Back of cab to rear edge of tool box (inches) _____

Rails on Bed

Height above side of bed (inches) _____

Light Bar on Roof

Need photo and dimensions noted above

Running Boards / Steps

Extending how far below factory body (inches) _____

Other features not listed

Describe in detail and include photo(s) and dimensions

DIMS 119A (12/99)



DIMENSION SHEET - PICKUP TRUCK

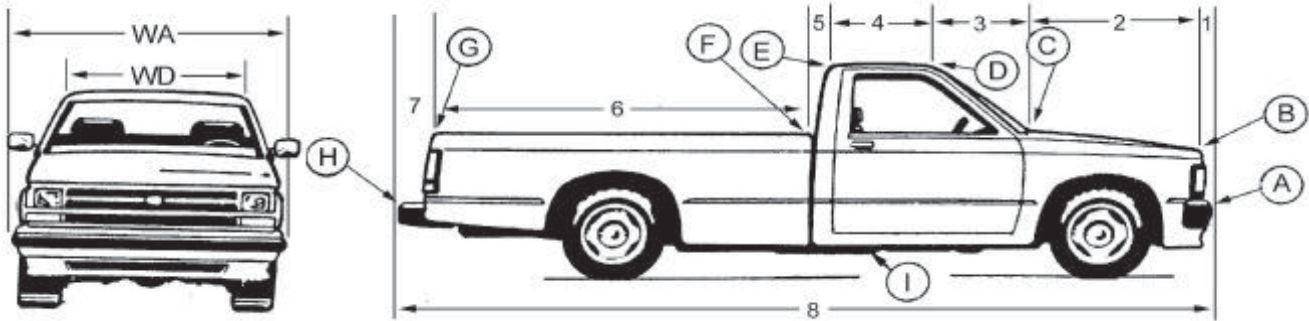

Lengths - Measured Horizontally

- # 1 Corner of front bumper to front of hood _____
- # 2 Front of hood to base of windshield _____
- # 3 Base of windshield to front of roof _____
- # 4 Front of roof to rear of roof _____
- # 5 Rear of roof to front of bed _____
- # 6 Front of bed to rear of bed _____
- # 7 Rear of bed to rear of bumper _____
- Total _____
- # 8 Overall length of pickup at corner of bumpers _____

Heights - Measured from Ground

- HA Height at "A" _____
- HB Height at "B" _____
- HC Height at "C" _____
- HD Height at "D" _____
- HE Height at "E" _____
- HF Height at "F" _____
- HG Height at "G" _____
- HH Height at "H" _____
- HI Height at "I" _____

If you have measured correctly, the total of # 1 through # 7 should be the same as # 8.

Widths, Measured Side to Side at Points Shown

- WA Width of front bumper at point "A" _____
- WB Width of front of hood at point "B" _____
- WC Width of hood at windshield base, point "C" _____
- WD Width of roof at point "D" _____
- WE Width of roof at point "E" _____
- WF Width bed at front, point "F" _____
- WG Width of bed at rear, point "G" _____
- WH Width of rear bumper at "H" _____

Draw in any accessories, noting the measurements and location (example - sun visor, light bar, tool box, etc.)

Vehicle Information

A photo of the vehicle will help us make the pattern. The photo can be returned if requested.

MAKE _____ Short bed
 MODEL _____ Long bed
 YEAR _____ Extra or extended cab
 NAME _____
 Daytime phone _____
 Date of order _____

DIMS 119 (12/99)



Custom Order Release

Please be advised that in placing this order for custom manufactured merchandise you are accepting full responsibility for the correctness and accuracy of all pertinent ordering information. Further, be advised that by filling out and signing this form you are affirming the correctness and accuracy of the information contained herein and authorizing Motor State Distributing to order this custom merchandise. Once this form has been signed, the purchaser assumes full responsibility for paying for the custom merchandise and no refund will be issued unless it can be shown that any errors or defects were the fault of the manufacturer and not caused by erroneous information.

As a rule, custom orders cannot be cancelled once the order is placed with the manufacturer. All custom orders are subject to freight and handling charges from the manufacturer.

No returns will be accepted on custom-built items.

Sales Contact At Motor State _____

Customer Number _____

Company Name _____

Address _____

City _____ State _____ Zip _____

Phone _____

Fax _____

Email _____

Print Your Name _____ Date _____

Authorized Signature _____

If you are submitting this form electronically, your digital signature must be added last. Once signed, this form becomes non-editable. Please double check all items first.

Motor State Distributing
8300 Lane Drive, Watervliet MI 49098

web: www.motorstate.com | phone: 1-800-772-2678 | fax: 1-800-772-2618