



Electric Brake Shut-Off Instructions

INSTRUCTIONS

Contents List:

- 1 - Electronic Shut-Off Valve
- 2 - 1/8" NPT To 3/16" Inverted Flare Fittings
- 2 - 1/8" NPT Plugs

1. Securely mount control valve to a panel or bracket in a location that provides easy connections to the right front brake line. Control valve can be mounted in any position.
2. Use Teflon thread sealer or tape when installing fittings into valve. Use caution to prevent contamination of sealer entering valve.
3. There are three inlet ports, install one of the included 3/16" inverted flare fitting into one of the ports and install the provided 1/8" NPT plugs in the two ports not used, see diagram.
4. Install the remaining 3/16" inverted flare fitting into the outlet port of the valve, see diagram.
5. Connect the brake line from the master cylinder to the inlet port of the valve. If you have a tee fitting to the front brakes, make certain valve is plumbed after the fitting. See diagram.
6. Connect the brake line from the right front brake to the outlet port of the valve.
7. Bleed system.
8. Once valve has been mounted and connected, remove top retaining nut and apply a small amount of blue thread locker and reassemble.
9. Connect the black wire from the valve to a reliable chassis ground.
10. Connect the red wire to a single pole switch (ALL99067) located within easy reach of the driver. Switch needs to be returned to 4 wheel brakes when not in use. CAUTION: If switch is left on for an extended period of time damage to solenoid will result. It is recommended to connect the 3 wheel brake switch to a separate switched power source to prevent damage.

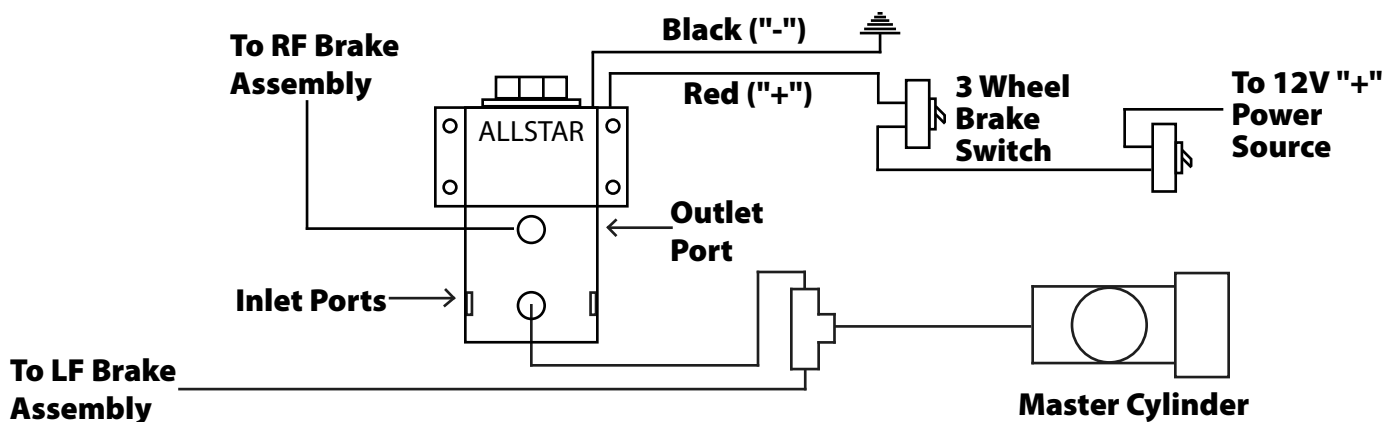

Allstar Performance 8300 Lane Dr., Watervliet, MI 49098
Phone: (269) 463-8000 Fax: (800) 772-2618 www.allstarperformance.com